

Final Solution

PRINT your student ID: \_\_\_\_\_

PRINT AND SIGN your name: \_\_\_\_\_, \_\_\_\_\_ \_\_\_\_\_  
(last name) (first name) (signature)

PRINT your discussion section and GSI(s) (the one you attend): \_\_\_\_\_

Name and SID of the person to your left: \_\_\_\_\_

Name and SID of the person to your right: \_\_\_\_\_

Name and SID of the person in front of you: \_\_\_\_\_

Name and SID of the person behind you: \_\_\_\_\_

**1. Which lab was your favorite lab in EE16A? (1 Point)**

**2. What are your plans for winter break? (1 Point)**

Do not turn this page until the proctor tells you to do so. You may work on the questions above.

PRINT your name and student ID: \_\_\_\_\_

**3. Mechanical Correlation (4 Points)**

Given  $\vec{a} = \begin{bmatrix} 1 \\ 2 \\ 3 \end{bmatrix}$  and  $\vec{b} = \begin{bmatrix} -1 \\ 1 \\ 1 \end{bmatrix}$ , and that  $\vec{a}$  and  $\vec{b}$  are both circular (repeating) signals, **indicate (by circling**

**it) which of the vectors below correspond to the cross correlation of  $\vec{a}$  with  $\vec{b}$ .**

(a)

$$\begin{bmatrix} 4 \\ 2 \\ 0 \end{bmatrix}$$

(b)

$$\begin{bmatrix} 5 \\ 3 \\ 1 \end{bmatrix}$$

(c)

$$\begin{bmatrix} 0 \\ 2 \\ 0 \end{bmatrix}$$

(d)

$$\begin{bmatrix} 1 \\ 4 \\ 2 \end{bmatrix}$$

PRINT your name and student ID: \_\_\_\_\_

**4. Mechanical Gram-Schmidt (5 Points)**

**Find a set of orthonormal vectors  $\{\vec{u}_1, \vec{u}_2\}$  that spans the same subspace as the set of vectors  $\{\vec{v}_1, \vec{v}_2\}$  given below. The vector  $\vec{u}_1$  must be a multiple of  $\vec{v}_1$ , that is  $\vec{u}_1 = \alpha \vec{v}_1$  for  $\alpha \in \mathbb{R}$ .**

$$\left\{ \vec{v}_1 = \begin{bmatrix} 1 \\ 1 \end{bmatrix}, \vec{v}_2 = \begin{bmatrix} 1 \\ 0 \end{bmatrix} \right\}$$

PRINT your name and student ID: \_\_\_\_\_

### 5. Capacitive Touch Revisited (18 Points)

In this problem, we will design a capacitive touch-sensing circuit without switches.

- (a) (4 Points) A capacitor with capacitance  $C$  is driven by a voltage source  $v_s(t)$  as shown below. **Derive an expression for the current through the capacitor  $i_C(t)$**  when the voltage source has the time-dependent value shown in the plot below (i.e.  $v_s(t) = k * t$  where  $k$  is the slope). Your expression for  $i_C(t)$  should be in terms of  $C$ ,  $V_0$ , and  $T_0$ . (Hint: Use nodal analysis and/or any other circuit analysis technique and the slope of  $v_s(t)$ .)

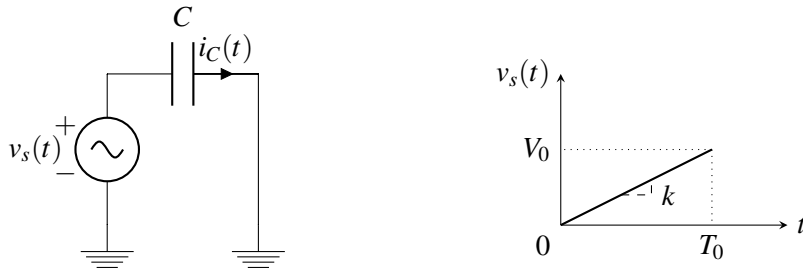

- (b) (2 Points) For this problem, we will model the finger touch as having increased the capacitance from  $C$  to  $C + \Delta C$ , as shown below. **Find the current  $i_C(t)$  for the new circuit shown below.**

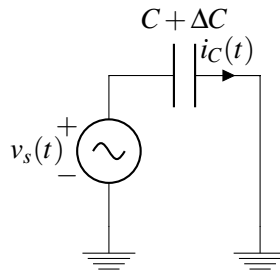

PRINT your name and student ID: \_\_\_\_\_

(c) (4 Points) **Derive an expression for  $v_o(t)$**  for the circuit below in terms of  $R$  and  $I(t)$ .

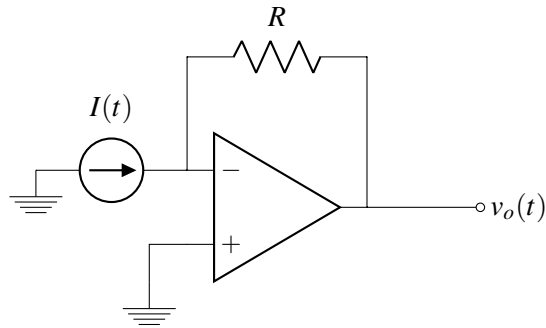

PRINT your name and student ID: \_\_\_\_\_

- (d) (8 Points) Now let's **design a circuit whose output voltage is proportional to the capacitance of the touch screen capacitor (i.e.,  $V_{\text{out}} = \alpha C_{\text{touch}}$ , where  $\alpha \in \mathbb{R}$ )**

You can only use the following components: the "ramp" voltage source  $v_s(t)$  from part (a), constant (DC) voltage sources, op-amps, resistors, and the touch screen capacitor ( $C_{\text{touch}}$ ). Clearly label all components that you use in your circuit. If you use a constant (DC) voltage source, clearly label its voltage. If you use the ramp voltage source, provide the value of its slope ( $k$ ).

PRINT your name and student ID: \_\_\_\_\_

**6. Eigenvectors (13 Points)**

Consider a matrix  $\mathbf{A} \in \mathbb{R}^{3 \times 3}$  with eigenvalues  $\lambda = 1, 2, 3$ , and corresponding eigenvectors  $\vec{v}_1, \vec{v}_2$  and  $\vec{v}_3$  respectively. Let the matrix  $\mathbf{B} = \mathbf{A}^3 - 6\mathbf{A}^2 + 11\mathbf{A} - 6\mathbf{I}$ .

(a) (5 Points) **Find  $\mathbf{B}\vec{v}$** , where  $\vec{v}$  is one of the eigenvectors of  $\mathbf{A}$ .

*Hint:*

$$\lambda^3 - 6\lambda^2 + 11\lambda - 6 = (\lambda - 1)(\lambda - 2)(\lambda - 3)$$

(b) (4 Points) **Find all the eigenvalues of the matrix  $\mathbf{B}$ .**

PRINT your name and student ID: \_\_\_\_\_

(c) (4 Points) **Write out the numerical values in the  $3 \times 3$  matrix  $\mathbf{B}$  and justify your answer.**



PRINT your name and student ID: \_\_\_\_\_

### 7. Measuring Currents (14 Points)

Your friends Elad and Anant, pleased with your help on Midterm 2, are working in lab and have another problem they need your help with. They found a current source in an unmarked box but have no idea what current it outputs.

Elad decided to attach 3 known resistors with varying values to the terminals of the current source and recorded the resistance and voltage across each resistor in the table below.

Resistor	Resistance	Voltage
$R_1$	$1\ \Omega$	$5\ \text{V}$
$R_2$	$3\ \Omega$	$15\ \text{V}$
$R_3$	$5\ \Omega$	$16\ \text{V}$

Below is the circuit he and Anant created.



- (a) (6 Points) Anant thinks that there must have been some noise in the measurements since they do not get the same current for every data point. Because of this, he and Elad would like you to **use least squares to approximate the value of the current source  $I$  given their data. Setup this least squares problem in the format  $A\vec{x} = \vec{b} + \vec{e}$ , where  $\vec{e}$  is the error vector, then find the vector  $\vec{x}$  that minimizes the norm of  $\vec{e}$ .**

PRINT your name and student ID: \_\_\_\_\_

- (b) (8 Points) Anant and Elad repeat this procedure many times and find the variation in measured voltage for each resistor is different. This implies they should "trust" certain measurements more than others. Because of this, Anant constructs a diagonal matrix of weights  $\mathbf{W}$ , where all of the weights (diagonal entries in the matrix) have non-zero values. They would now like to find the vector  $\vec{x}$  that minimizes the weighted error  $\vec{e}_w = \mathbf{W}\vec{e}$ . This amounts to solving the following optimization problem

$$\min_{\vec{x}} \|\mathbf{W}(\mathbf{A}\vec{x} - \vec{b})\|$$

**In terms of  $\mathbf{W}$ ,  $\mathbf{A}$ , and  $\vec{b}$  find the vector  $\vec{x}$  that minimizes the norm of  $\vec{e}_w$ .** Do not plug in any values for  $\mathbf{A}$ ,  $\mathbf{W}$ , or  $\vec{b}$  - i.e. your result should be symbolic. Do not use calculus in your solution.

PRINT your name and student ID: \_\_\_\_\_

**8. IoT4eva version ∞ (18 Points)**

IoT4eva is working on their newest device, and in order to meet their form factor targets, they end up putting a cable in between the power module (that includes a simplified version of the voltage regulator you designed previously) and their electronics. This cable has substantial resistance associated with it, and the resulting circuit model is shown below. Through this problem, you may assume the rails of the op amp are sufficiently large in magnitude to not affect the operation of the circuit.

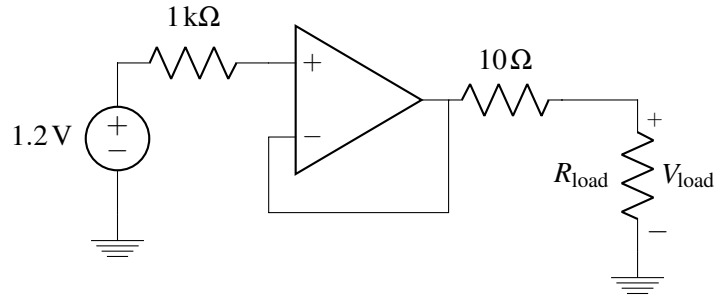

- (a) (4 Points) The goal of the linear regulator is to provide a constant voltage across the  $R_{load}$  resistance (which models the electronics) independent of the value of  $R_{load}$ . **As a function of  $R_{load}$ , for the circuit shown above, what will be the value of  $V_{load}$ ?**

PRINT your name and student ID: \_\_\_\_\_

- (b) (4 Points) One of your colleagues starts exploring the use of a "UCBMFET" device (which has three terminals) to try and improve the situation. The circuit model for a UCBMFET is shown below inside the dotted lines. **For the circuit shown below, what is the value of  $i_{out}$  as a function of  $R_{load}$ ,  $V_c$  and  $g_m$ ?**

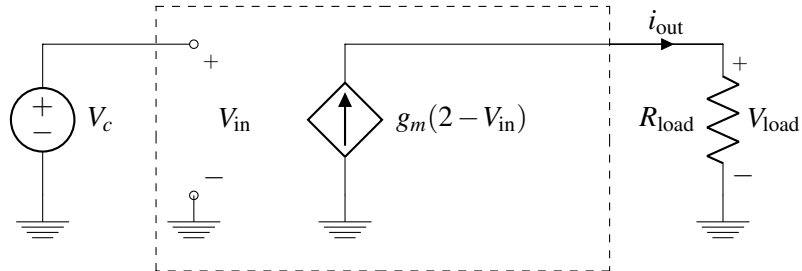

PRINT your name and student ID: \_\_\_\_\_

- (c) (10 Points) Another one of your colleagues thinks they can achieve a constant voltage across  $R_{load}$  by combining the UCBMFET (placed on the same side of the cable as the electronics) with a modified version of the original regulator circuit. Your colleague started the design and came up with the incomplete circuit shown below.

Recalling that your goal is to design a circuit that will produce a constant voltage across  $R_{load}$  (where that voltage does not depend on the resistance of  $R_{load}$ ), **complete the circuit shown below by adding in a single wire that connects one of the nodes to the second input terminal of the op-amp, and fill in the boxes to indicate which of the op-amp inputs is positive (+) and which is negative (-). What is the voltage that your circuit would then produce across  $R_{load}$ ?**

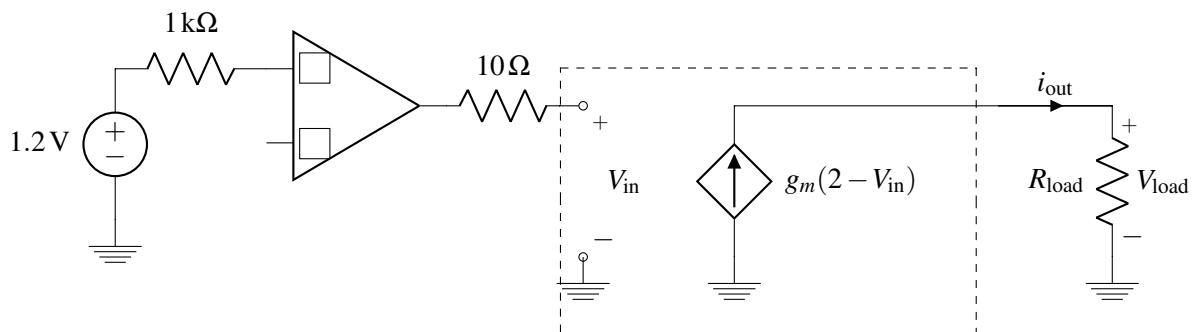

PRINT your name and student ID: \_\_\_\_\_

### 9. STOMP Imaging (14 Points)

In the imaging lab, we projected masks onto objects and measured reflected light to create a single pixel camera. To image a  $30 \times 40$  image, we created 1200 masks and took 1200 measurements.

We are going to image objects using a smaller set of masks, in this case, only 600 masks. Let the matrix  $\mathbf{M}$  be the  $600 \times 1200$  matrix of masks, where every mask is a row. Let the vector  $\vec{i}$  of length 1200 represent the image and the vector  $\vec{b}$  of length 600 represent what we measure after applying the masks. Concisely,

$$\vec{b} = \mathbf{M}\vec{i}$$

Assume that we have constructed the mask matrix  $\mathbf{M}$  such that its columns are approximately orthogonal and have norm  $N$ . That is, if  $\vec{v}_i$  and  $\vec{v}_j$  are columns of  $\mathbf{M}$ , then  $\langle \vec{v}_i, \vec{v}_j \rangle \leq \epsilon$  for some small  $\epsilon$  when  $i \neq j$ . Furthermore, for all  $i$ ,  $\langle \vec{v}_i, \vec{v}_i \rangle = N^2$ .

- (a) (3 Points) Because the number of pixels (1200) is greater than the number of masks (600), **is it possible that multiple distinct images,  $\vec{i}$ , give you the same measurements,  $\vec{b}$ ? Justify your answer.**

- (b) (3 Points) Let the  $\vec{m}_j$  be the  $j$ 'th column of the matrix  $\mathbf{M}$  and suppose the image contained only one pixel with magnitude  $\alpha$ , i.e. the entries in  $\vec{i}$  are 0 everywhere except for entry  $k$  which has value  $\alpha$ . **For this  $\vec{i}$ , find the vector  $\vec{b}$  in terms of the columns of the matrix  $\mathbf{M}$ .**

PRINT your name and student ID: \_\_\_\_\_

- (c) (3 Points) If you know that the image contains only one pixel at entry  $k$ , **show that the inner product  $\langle \vec{m}_i, \vec{b} \rangle$  is maximized at  $i = k$**

- (d) (5 Points) Now suppose there are multiple pixels in the image, however the image is sparse. Using OMP, we could find which pixels were contained in the image. However, we would like to image faster, and so at every iteration of OMP, rather than picking the column of  $\mathbf{M}$  with the largest inner product, we will pick all columns of  $\mathbf{M}$  which have inner products greater than some threshold  $y_{\text{magic}}$ . This procedure is known as Stagewise OMP or STOMP.

Suppose that we run STOMP, selecting more than one pixel at each iteration. During the first 3 iterations, we find 13 pixels (1st iteration), 17 pixels (2nd iteration), and 4 pixels (3rd iteration). Recall that in the OMP procedure, we compute the projection  $\mathbf{A}(\mathbf{A}^T \mathbf{A})^{-1} \mathbf{A}^T \vec{b}$  at every iteration so that we can compute the residual  $\vec{b}$ . **At each of the first 3 iterations what is the size of the  $\mathbf{A}$  matrix? What do the columns of  $\mathbf{A}$  represent?**

**10. Message Received! (14 Points)**

Pat and Lucy are aspiring freshmen taking EE16A. They both live on opposite sides of Unit 2, but they want to communicate with each other. Worried about eavesdropping on WiFi or cellular data, they come up with a secure communication scheme using Gold codes.

Lucy devises a Gold code  $\vec{c}_p$  that has some unique properties and shares it with Pat. The Gold code is a sequence of  $+1$  or  $-1$  of length  $N$ . In order to send Pat a message, Lucy multiplies the Gold code  $\vec{c}_p$  by a number  $x$ , and transmits  $x\vec{c}_p$ . Pat and Lucy want to communicate in binary, so  $x$  only takes the value  $+1$  or  $-1$ .

Lucy designed the Gold codes such that the sum of the entries in  $\vec{c}_p$  is equal to zero (i.e. the code has a mean of zero). Furthermore, the autocorrelation of the code  $\vec{c}_p$  is 1 for no time shift and has magnitude less than or equal to 0.1 for all other time shifts. Recall that  $\vec{c}_p^{(k)}$  denotes that the vector  $\vec{c}_p$  is circularly shifted by  $k$  and that  $\vec{c}_p[n]$  denotes the  $n$ 'th entry in the vector  $\vec{c}_p$ . These properties are expressed mathematically below.

$$\frac{1}{N} \sum_{n=0}^{N-1} \vec{c}_p[n] = 0 \qquad \frac{1}{N} \left| \langle \vec{c}_p, \vec{c}_p^{(k)} \rangle \right| = 1 \text{ if } k = 0 \qquad \frac{1}{N} \left| \langle \vec{c}_p, \vec{c}_p^{(k)} \rangle \right| \leq 0.1 \text{ if } k \neq 0$$

Pat made a receiver whose output  $\hat{x}$  should be equal to Lucy's messages. Throughout this problem, we will assume that Pat's receiver is synchronized with Lucy's transmission, that is when Lucy transmits  $x * \vec{c}_p$ , Pat also receives  $\vec{r} = x * \vec{c}_p$  (i.e. no shift). Pat's receiver performs the inner product between the received signal,  $\vec{r}$ , and  $\vec{c}_p$  to generate  $y$ . If  $y$  is greater than 0,  $\hat{x} = 1$ , and Pat knows Lucy was trying to send a  $+1$ . If  $y$  is less than 0,  $\hat{x} = -1$ , and Pat knows Lucy was trying to send a  $-1$ . The properties of Pat's receiver are summarized below.

Received Signal	Inner Product	Receiver Output
$\vec{r} = x * \vec{c}_p$	$y = \langle \vec{r}, \vec{c}_p \rangle$	$\hat{x} = \begin{cases} +1, & \text{if } y > 0 \\ -1, & \text{if } y < 0 \end{cases}$



PRINT your name and student ID: \_\_\_\_\_

- (a) (6 Points) While Lucy and Pat are happily enjoying their secure chatting, Professor Miki Lustig starts operating his ham radio. Pat now starts picking up both Lucy's signal and Miki's signal. The input to Pat's receiver can be modeled as a sum of Lucy's signal  $\vec{c}_p$  and Miki's interference signal  $\vec{i}$ , i.e.,  $\vec{r} = x * \vec{c}_p + \vec{i}$ . We further assume that Miki's signal is constant during one period of the Gold code, so  $\vec{i}[n] = T$  for all  $n$  and some real number  $T$ . **Will Pat still be able to recover Lucy's messages? Justify your answer**

Hint: Recall that Lucy's Gold codes have a mean of 0, that is

$$\frac{1}{N} \sum_{n=0}^{N-1} \vec{c}_p[n] = 0$$

PRINT your name and student ID: \_\_\_\_\_

- (b) (8 Points) An Alien spaceship lands in Oakland and Lucy and Pat's transmissions are reflecting off this spaceship. This results in two paths for the signal from Lucy to Pat, as shown in Figure 10.1.

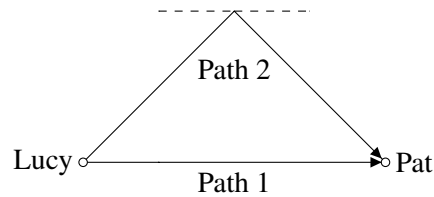

Figure 10.1: Two paths from Lucy to Pat

Path 1 is the same as in part (a). Path 2 is a reflected path that causes another copy of the signal to arrive at a delay  $\ell$  with strength  $\beta$ . With these two paths, the input to Pat's receiver  $\vec{r}$  is given below. We assume here that the delay  $l$  is less than one period of the Gold codes, i.e.  $0 \leq \ell < N$ .

$$\vec{r} = x * \vec{c}_p + \beta * x * \vec{c}_p^{(\ell)}$$

**What is the largest value of  $\beta$  for which Pat's receiver can still correctly recover Lucy's message (i.e.,  $\hat{x} = x$ )?** Hint: Recall that the inner product of Lucy's Gold Code with a shifted version of itself has an absolute value less than or equal to 0.1. That is:

$$\frac{1}{N} \left| \langle \vec{c}_p, \vec{c}_p^{(k)} \rangle \right| = 1 \text{ if } k = 0$$

$$\frac{1}{N} \left| \langle \vec{c}_p, \vec{c}_p^{(k)} \rangle \right| \leq 0.1 \text{ if } k \neq 0$$